

ROBUSTA

LA POMPA CORAZZATA

THE ARMORED PUMP



SISTEMI DI POMPAGGIO PER L'INGEGNERIA CIVILE E IL DRENAGGIO DEL TERRENO
PUMPING SYSTEM FOR CIVIL ENGINEERING AND WELLPOINT

Le pompe della serie ROBUSTA sono pompe centrifughe con girante aperta ad alto rendimento idraulico, internamente corazzate per resistere all'azione abrasiva e corrosiva di liquidi carichi con materiali in sospensione.

Tutti i liquidi con particelle solide, siano esse grandi o piccole, dure o filamentose possono essere agevolmente pompate da queste macchine: acqua fangosa, fanghi bentonitici, acqua di drenaggio, di falda, di laghi, di fiume, fognature, ecc.

Sono costruite nelle seguenti versioni:

- Serie EASY leggera, in alluminio per il pronto intervento in piccoli scavi, (pag. 3).
- Serie RB Robusta in ghisa per servizio continuativo, (pag. 4-5).
- Serie RW Vuoto assistite per impianti wellpoint o aspirazioni lunghe o profonde, (pag. 6).

The pumps belonging to the Robusta series are centrifugal, with open impeller and high efficiency, with internal "armoured-shield" to resist to abrasive and corrosive action of liquids with solids in suspension.

Any liquid with solids in suspension, large or small, hard or soft, filamentous, can be easily pumped by these machines: muddy water, bentonite sludge, bilge water, sawdust muds...

Available in the following series:

- *EASY light, aluminium construction, for first emergency in small diggings, (pag. 3).*
- *RB use-proof, cast iron construction for continuous service, (pag. 4-5).*
- *RW vacuum assisted, for wellpoint plants and long or deep suction, (pag. 6).*

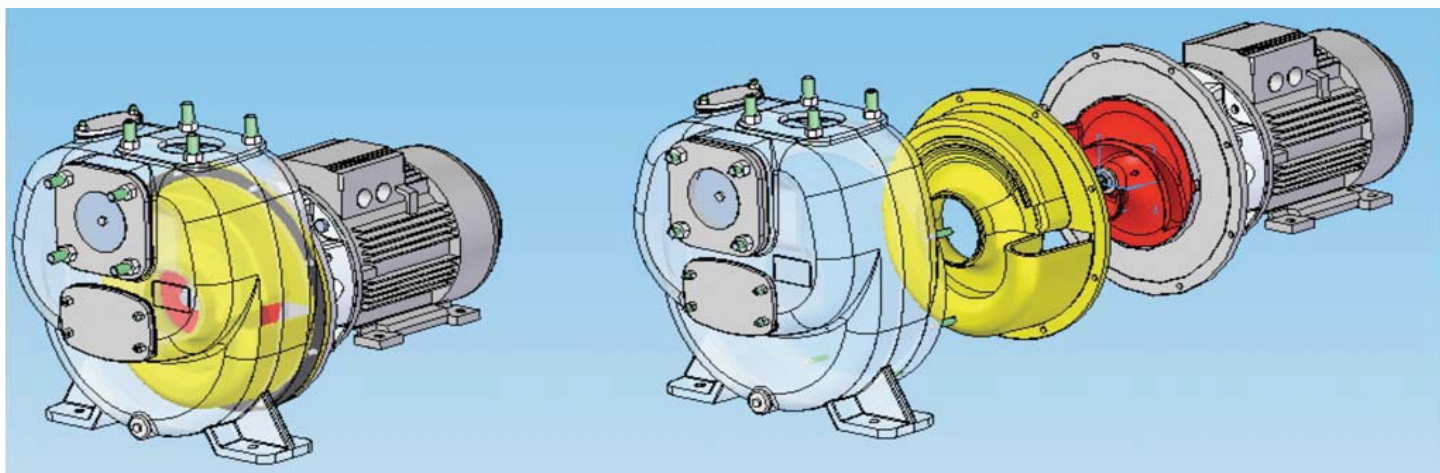

VOLUTA VOLUTE

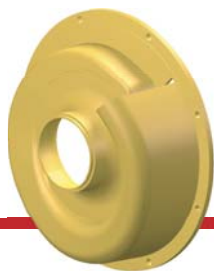

La corazza a forma di voluta situata all'interno e fissata al corpo senza viti interne è di materiale resistente all'abrasione nella versione standard, oppure in materiale molto duro nei casi particolarmente difficili.

The volute shaped internal shield is fused from very hard and abrasion proof metals, according to the final use, and is connected to the casing without using screws.

GIRANTE IMPELLER



La girante ad alto rendimento idraulico in ghisa dura garantisce un largo passaggio dei corpi solidi e una notevole resistenza all'azione abrasiva.

The double curved impeller has a very high hydraulic performance, fused in hard cast iron, allows a large solid passage and is very resistant to abrasion.

TENUTA MECHANICAL SEAL

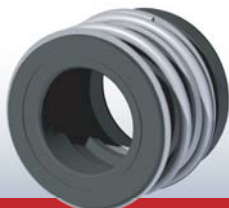

La tenuta meccanica è fondamentale per il buon funzionamento della pompa, in particolare nella fase di autoadescamento, è in materiale molto duro e dotata di un sistema di raffreddamento che ne garantisce il funzionamento anche in casi difficili.

The mechanical seal is fundamental for the performance of the pump, with bigger importance during the priming phase; it's hard metal built and it has a life-lasting cooling system that guarantees the functionality in any condition.

Motopompe leggera su barella Serie EASY

Self-priming pumps on hand frame EASY Serie

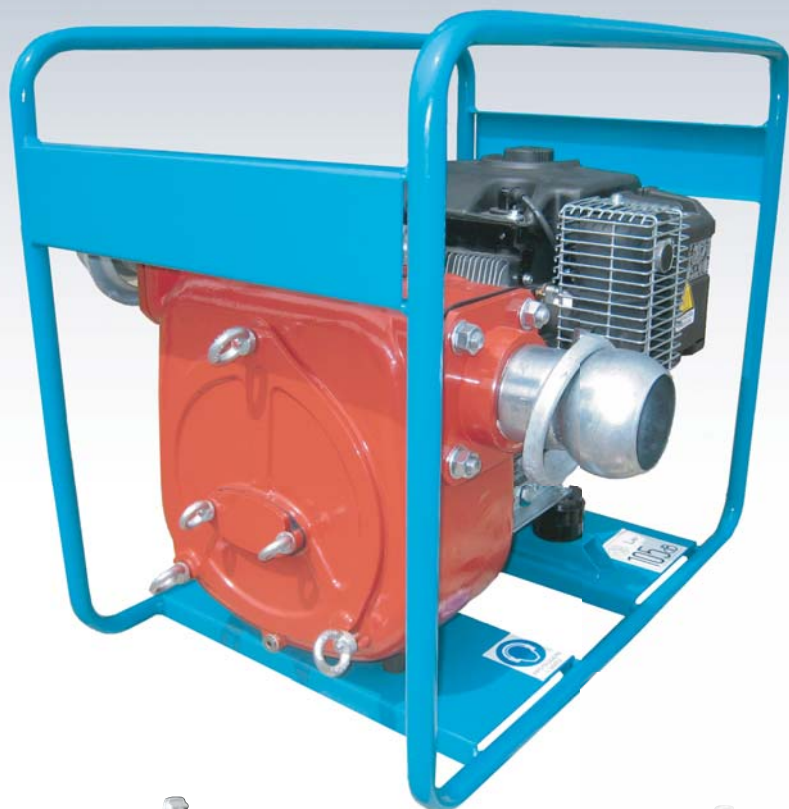

Motopompe leggera in alluminio resistente anche all'acqua salata. Facilmente trasportabili per svuotamento di scavi, fognature, sotto passi, ecc...

La corazza interna in materiale resistente all'abrasione è facilmente smontabile per ispezione e pulizia della macchina senza dovere smontare le tubazioni.

E' dotata di portina per l'ispezione interna senza dovere aprire la pompa.

Agile motorpumps in aluminium, sea-waterproof.

Easily transportable to empty diggings, sewerage, underpasses etc...

The internal volute shield is easy to be inspected and removed for full cleaning, without need to uncouple the pipes!

It comes with a small inspection door for first fast internal check.

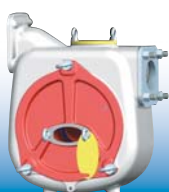

Possibilità di ispezione interna senza uso di utensili particolari

Easy tooling-free internal inspection

Facile e totale pulizia aprendo il portellone senza l'uso di utensili e senza smontare le tubazioni

Easy and total internal cleaning without needing to remove the hoses

Disco voluta riportato facilmente sostituibile

Reported volute plate easy to be replaced

MOTOPOMPE AUTOADESCANTI LEGGERE su barella ENGINE-DRIVEN LIGHT SELF-PRIMING PUMPS on hand frame

tipo type	codice code	bocche ports inch/mm	solidi solids mm	portata delivery mc/h					motore engine	cil. disp cm ³	giri/min RPM	avv. starter
				prevalenza head m		10	30	50				
RB316	RB316BALLA28+G	3"/80	32	29	23	17	11	5	Lomb. LGA280	280	3000	man
	RB316AALBS24+G			34	28	22	15	9	B.S. 245432	360	3000	man
	RB316BALHN27+G			30	24	18	12	6	Honda GX270	270	3000	man
	RB316BALBS18+G			29	23	17	11	5	B.S. 185432	280	3000	man
	RB316BALHN24+G			23	17	11	5	-	Honda GX240	242	3000	man
				30	60	100	140	160				
RB416	RB416AALBS30+G	4"/100	50	22	20	16	12	10	B.S. 303442	450	3000	man
	RB416BALLA34+G			17	15	10	6	4	Lomb. LGA 340	340	3000	man
	RB416BALBS24+G			19	16	12	8	6	B.S. 245432	360	3000	man
	RB416BALHN39+G			19	16	12	8	6	Honda GX390	389	3000	man

Motopompe carrellate Serie RB

Engine driven self-priming pumps on trailer RB Serie

VERSIONE + T

Motopompe centrifughe autoadescanti professionali in ghisa, motorizzate con motori diesel, su carrello con telaio semplice e assale a due ruote pneumatiche. Disponibili con avviamento a strappo o elettrico, tubazioni flessibili di aspirazione e manichette di mandata con raccordi rapidi e filtro di fondo.



+ T VERSION

Professional self-priming centrifugal pumps in cast iron, with diesel engine on simple 2 wheels trailer. Available electric or manual starter, flexible hoses for suction and delivery, rapid couplings and suction strainer.



MOTOPOMPE AUTOADESCANTI su carrello semplice DIESEL-DRIVEN SELF-PRIMING PUMPS on simple trailer													
tipo type	codice code	bocche ports inch/mm	solidi solids mm	portata delivery m ³ /h					motore engine	cil. disp cm ³	giri/min RPM	kW	avv. starter
				prevalenza head m		10	20	30					
RB216	RB216AGLD44 +T	2"/50	25	30	25	18	11	5	Lomb. 15LD440	442	3000	6	man *
	RB216BGLD35 +T			23	19	13	5	-	Lomb. 15LD350	349	3000	4	man *
RB220	RB220AGLD33 +TE	2"/50	25	50	45	38	28	15	Lomb. 25LD330-2	654	3000	9	el
	RB220BGLD50 +T			40	36	30	32	12	Lomb. 15LD500	505	2700	7	man *
				20	40	60	80	90					
RB316	RB316AGLD44 +TE	3"/80	34	28	25	20	15	5	Lomb. 15LD440	442	3000	6	man *
	RB316AGYN10 +TE			28	25	20	15	5	Yanmar L100V	435	3000	6	el
	RB316BGLD35 +T			20	17	13	5	-	Lomb. 15LD350	349	3000	4	man *
RB320	RB320AGLD42 +TE	3"/80	35	38	36	32	27	15	Lomb. 25LD425-2	851	3000	9	el
	RB320BGLD50 +T			25	19	14	6	4	Lomb. 15LD500	505	2400	6	man *
RB325	RB325BGLD42 +TE	3"/80	35	26	25	22	18	5	Lomb. 25LD425-2	851	1600	5	el
	RB325AGLD62 +TE			48	42	38	30	15	Lomb. 9LD626-2	1248	2700	17	el
				30	60	100	140	160					
RB416	RB416AGLD42 +TE	4"/100	50	24	21	20	14	5	Lomb 25LD425/2	851	3000	11	el
	RB416BGLD33 +TE			18	15	12	5	-	Lomb 25LD330/2	654	3000	7	el

* DISPONIBILE AVV. ELETTRICO - EL. STARTER AVAILABLE

Costruzione in ghisa, corazza interna in ghisa sferoidale senza viti, girante ad alto rendimento idraulico a largo passaggio, tenuta meccanica in metallo duro con particolare sistema di raffreddamento.

Motopompe carrellate Serie RB

Engine driven self-priming pumps on trailer RB Serie

VERSIONE + TT

Motopompe centrifughe autoadescanti professionali in ghisa, motorizzate con motori diesel, montate su carrello con serbatoio combustibile incorporato per una autonomia di funzionamento di almeno 12 ore e assale a due ruote pneumatiche. Fornibili anche in versione insonorizzata LW(A) 100. Disponibili tubazioni flessibili di aspirazione e manichette di mandata con raccordi rapidi e filtro di fondo.

+ TT VERSION

Professional self-priming centrifugal pumps in cast iron, with diesel engine on heavy duty 2 wheels trailer with incorporated fuel tank, for at least 12 hours of continuous working. Available in sound-proof version LW(A) 100. Flexible hoses for suction and delivery rapid couplings and suction strainer on request.

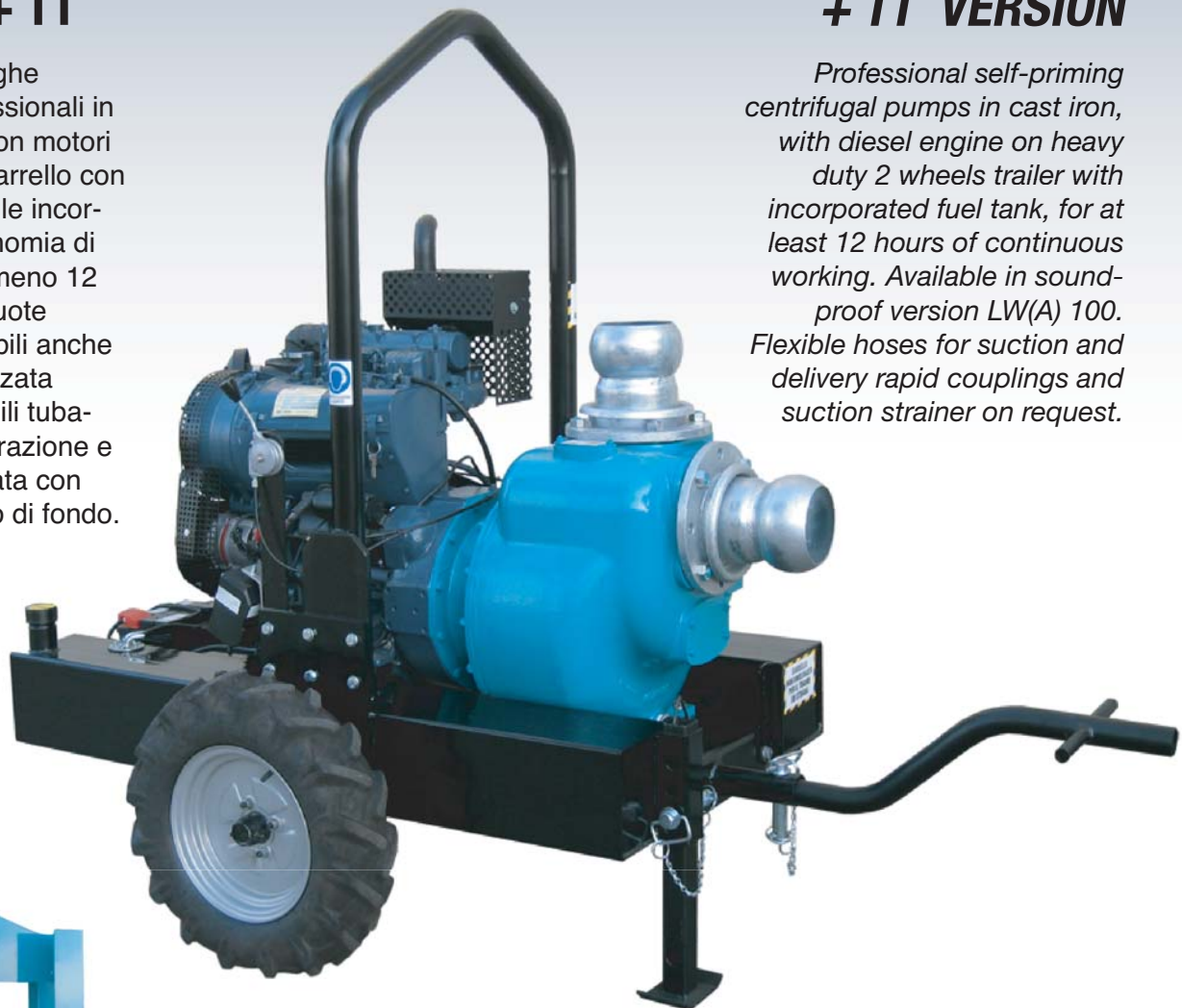

Cast iron construction, internal nodular cast iron volute - plate, without screws, high hydraulic performance impeller with large solid passage, hard metal mechanical seal with innovative cooling system .

MOTOPOMPE AUTOADESCANTI su carrello serbatoio DIESEL-DRIVEN SELF-PRIMING PUMPS on tank trailer													
tipo	codice code	bocche ports inch/mm	solidi solids mm	portata delivery m ³ /h					motore engine	cil. disp cm ³	giri/min RPM	kW	avv. starter
				prevalenza head m									
				50	80	100	120	150					
RB425	RB425BGLD62 +TT	4"/100	40	20	18	14	10	5	Lomb. 9LD626-2	1248	1700	11	el
	RB425AGLD63 +TT			28	26	20	15	7	Lomb. 9LD626-2	1870	2000	20	el
	RB425AGLDW16 +TT			26	23	18	13	6	Lomb. LOW 1603	1649	1900	18	el
				100	150	200	250	300					
RB625	RB625AGVM2 +TT	6"/150	73	25	23	18	11	6	VM SUN2105	1990	2000	33	el
	RB625AGVM3 +TT			35	32	25	15	8	VM SUN3105	2985	2400	56	el
	RB625BGLD62 +TT			14	13	10	6	3	Lomb. 9LD626-2	1248	1400	10	el
	RB625AGPKSIL +TT			25	23	18	11	6	PERKINS 404C22 *	2216	2000	31	el
	RB625BGPKSIL +TT			15	14	11	7	4	PERKINS 404C15 *	1508	1500	12	el
				100	200	300	400	500					
RB831	RB831AGVM4T+TT	8"/200	70	32	30	28	25	20	VM SUN4105T	3980	1800	80	el
	RB831BGVM3T+TT			22	20	19	17	13	VM SUN3105T	2985	1500	45	el

* VERSIONE INSONORIZZATA - SILENCED VERSION

Pompe vuoto - assistite per drenaggio Serie RW

Vacuum-assisted pumps Wellpoint System W+TT Series

SERIE RW

Motopompe ed elettropompe centrifughe in ghisa dotate di depressore volumetrico ad alto vuoto lubrificato ad olio, che garantisce un sicuro e rapido innescamento automatico in qualunque situazione, anche con tubazioni di aspirazione molto lunghe.

Carrello con serbatoio incorporato per una autonomia di almeno 12 ore. Disponibili anche nella versione insonorizzata LW(A)100.

Dotabili di tubazioni flessibili di aspirazione e manichette di scarico con raccordi rapidi.

RW SERIE

Construction in cast iron, assembled with high performances volumetric vacuum pump oil lubricated.









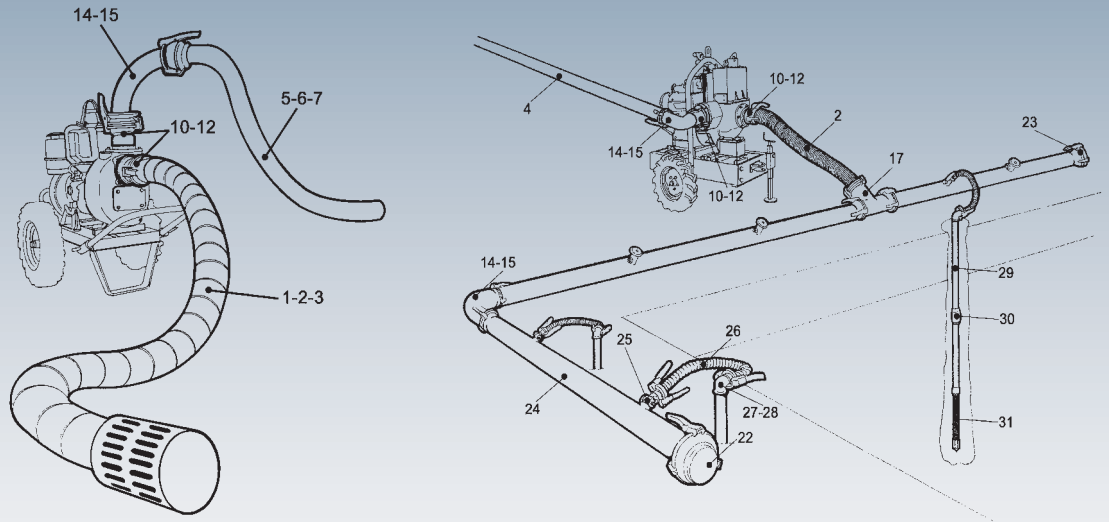

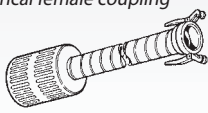
A rapid automatic priming is guaranteed in any situation, even with very long suction pipes. Trailer with diesel tank incorporated for an autonomy of 12 hours or more. These pumps can be supplied also in soundproof LW(A)100 version, and can be equipped with flexible suction and delivery hoses with quick couplings.

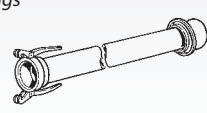
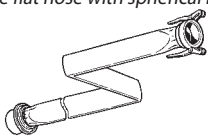

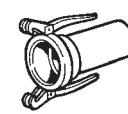
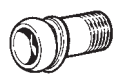
POMPE CON MOTORE ELETTRICO			PUMPS WITH ELECTRIC MOTOR						
tipo type	codice code	bocche ports	portata m3/h					giri/min RPM	kW
			prevalenza m						
			20	50	80	110	150		
W40	W40S/T54+TQ	4"/100	16	14	10	6	2	1450	5,5
	W40T74+TQ		20	18	14	10	5	1450	7,5
			60	120	180	240	300		
W60	W60T114+TQ	6"/150	17	14	11	8	5	1450	11
	W60S/T154+TQ		22	20	17	13	9	1450	15
			100	200	300	400	500		
RW831	RW 831AGT+TQ	8"/200	22	20	19	17	13	1450	22

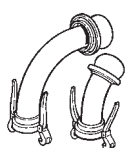
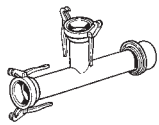
POMPE CON MOTORE DIESEL			DIESEL PUMPS						
tipo type	codice code	bocche ports	portata m3/h					motore engine	
			prevalenza m						
			60	80	100	120	150		
W41	W41MLD62+TT	4"/100	28	25	22	19	14	Lomb. 9LD626-2	
	W41MDZ2+TT		28	25	22	19	14	Deutz F2L2011 L	
	W41MVM2+TT		28	25	22	19	14	VM SUN 2105	
			150	200	250	300	350		
W61	W61MVM2+TT	6"/150	23	20	17	13	7	VM SUN 2105	
	W61MVM3+TT		29	26	23	20	14	VM SUN 3105	
	W61MDZ2+TT		20	17	14	10	5	Deutz F2L2011 L	
			100	200	300	400	500		
RW831	RW831BGVM3T+TT	8"/200	22	20	19	17	20	VM SUN 3105T	
	RW831AGVM4T+TT		32	30	28	25	23	VM SUN 4105T	

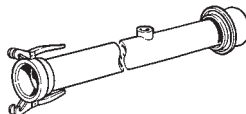
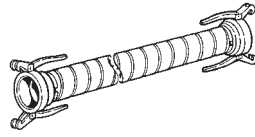

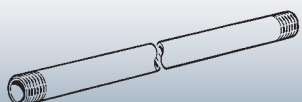
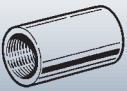
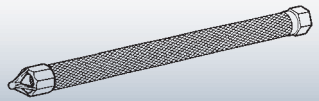
<p>01 Tubazione flessibile in PVC con spirale in acciaio per aspirazione con raccordo sferico femmina e filtro Suction hose with strainer, in PVC with steel spiral and spherical female coupling</p> 	<p>02 Tubazione flessibile in PVC con spirale in acciaio per aspirazione con raccordi sferici maschio/femmina Suction hose in PVC with steel spiral and spherical male/female couplings</p> 	<p>04 Tubazione rigida scarico in acciaio zincato con raccordi sferici maschio/femmina Discharge pipe with spherical male/female couplings</p> 
<p>06 Manichetta flessibile per scarico con raccordi sferici maschio/femmina Discharge flat hose with spherical male and female coupling</p> 	<p>08 Raccordo sferico maschio portagomma Male hose fitting</p> 	<p>09 Raccordo sferico femmina portagomma Female hose fitting</p> 
<p>10 Raccordo sferico maschio filettato Threaded male coupling</p> 	<p>11 Raccordo sferico femmina filettato Threaded female coupling</p> 	<p>12 Raccordo sferico maschio flangiato Flanged male coupling</p> 
<p>14/15 Curva 90° / 45° con raccordi sferici maschio/femmina 90° / 45° elbow</p> 	<p>17 Deviazione a T con raccordi sferici femmina/femmina/maschio Female / female / male Tee fitting</p> 	<p>22 Tappo sferico maschio Male cap</p>  <p>23 Tappo sferico maschio Male cap</p> 
<p>24 Collettore Wellpoint con attacchi e raccordi sferici maschio/femmina Wellpoint hose with connections and spherical male / female couplings</p> 	<p>26 Manicotto flessibile di collegamento con raccordi sferici femmina/femmina Flexible swing hose with spherical female / female couplings</p> 	<p>27/28 Manicotto con raccordo sferico Riser adaptor with spherical coupling</p> 
<p>29 Tubo di prolungamento per punta Wellpoint Extension pipe for Wellpoint</p> 	<p>30 Manicotto collegamento tubo Wellpoint Pipe coupling</p> 	<p>31 Filtro Wellpoint Wellpoint filter</p> 

Versione EASY
EASY Version

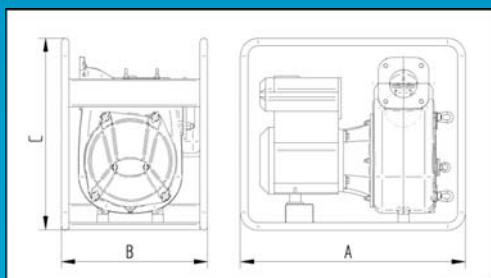

Codice Code	A	B	C	Peso Weight Kg.
RB 316A - RB 316B	800	520	680	61
RB 416A - RB 416B	800	520	680	72

Dimensioni in mm, non impegnative.

Versione +T
+T Version

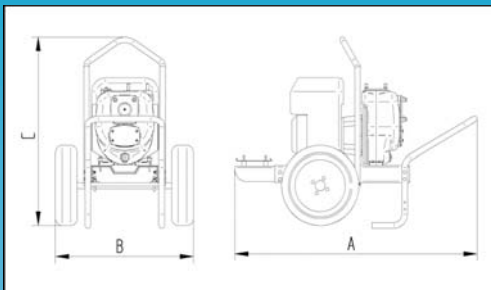

Codice Code	A	B	C	Peso Weight Kg.
RB216AGLD44 +T	1424	820	1085	150
RB216BGLD35 +T	1424	820	1085	135
RB220AGLD33 +TE	1424	820	1085	170
RB220BGLD50 +T	1424	820	1085	150
RB316AGLD44 +TE	1424	820	1085	165
RB316AGYN10 +TE	1424	820	1085	154
RB316BGLD35 +T	1424	820	1085	150
RB320AGLD42 +TE	1424	820	1085	165
RB320BGLD50 +T	1424	820	1085	155
RB325AGLD62 +T	1424	820	1085	175
RB325BGLD42 +TE	1424	820	1085	165
RB416AGLD42 +TE	1424	820	1085	195
RB416BGLD33 +TE	1424	820	1085	180

Dimensioni in mm, non impegnative.

Versione +TT
+TT Version

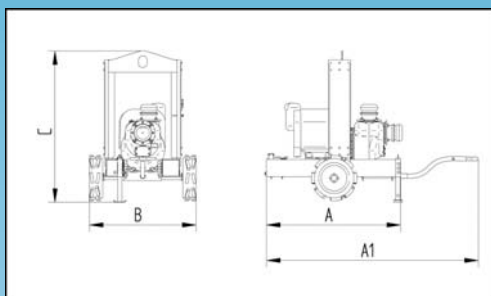

Codice Code	A	A1	B	C	Peso Weight Kg.
RB425AGLD626+TT	1562	2462	1240	1748	550
RB625AGVM2+TT	1560	2462	1240	1748	651
RB625BGLD626+TT	1560	2462	1240	1748	635
RB625AGPKSIL+TT	1560	2462	1240	1748	690
RB625BGPKSIL+TT	1560	2462	1240	1748	670
RB831AGVM4T+TT	2100	2860	1590	1820	1250

Dimensioni in mm, non impegnative.

Serie RW
RW Serie

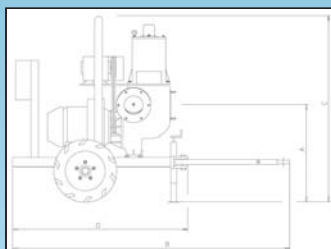

Codice Code	A	B	C	D	Peso Weight Kg.
W40S/T54 +TQ	600	2150	1540	1500	650
W40T74 +TQ	600	2150	1540	1500	650

Dimensioni in mm, non impegnative.

Codice Code	A	B	C	D	Peso Weight Kg.
W 60T114 +TQ	600	2150	1540	1500	700
W 60S/T154 +TQ	600	2150	1540	1500	800

Dimensioni in mm, non impegnative.

Serie RW
RW Serie

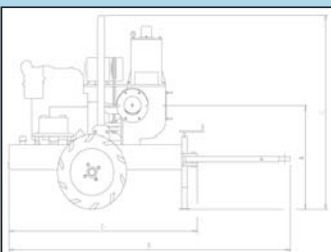

Codice Code	A	B	C	D	Peso Weight Kg.
W41MLD62+TT	1000	2400	1725	1510	800
W41MLD62+TT	1000	2600	1725	1710	850
W41MLD62+TT	1000	2400	1725	1510	850

Dimensioni in mm, non impegnative.

Codice Code	A	B	C	D	Peso Weight Kg.
W61MVM2+TT	1000	2400	1725	1510	840
W61MVM3+TT	1000	2600	1725	1710	995
W61MDZ2+TT	1000	2400	1725	1510	795

Dimensioni in mm, non impegnative.



www.robusta.eu
info@robusta.eu
sales@robusta.eu
 Tel. 049 8019783
 Fax. 049 8016346

VIESSE POMPE SRL - PADOVA - ITALY
info@viessepompe.it www.viessepompe.it

Distribuito da:

Distributed by:

